

MV-ID6120PM-00C-NNG

12 MP Smart Code Reader



Introduction

With built-in code reading algorithm, MV-ID6120PM-00C-NNG smart code reader can read different types of 1-dimensional code and 2-dimensional code with reading speed up to 84 codes/sec. It adopts deep learning algorithm to process images with good robustness, and can recognize various poor printing quality codes.

Available Model

MV-ID6120PM-00C-NNG

Applicable Industry

Express delivery and logistics, airport, e-commerce warehouse, etc.

Key Feature

- Adopts 12 MP sensor to provide high-quality images.
- Flexible installation and convenient debugging.
- Supports continuous reading of various codes without stopping.
- Supports recognizing various poor printing quality codes.
- Supports networking of multiple devices.
- Ingress protection 67.

Dimension

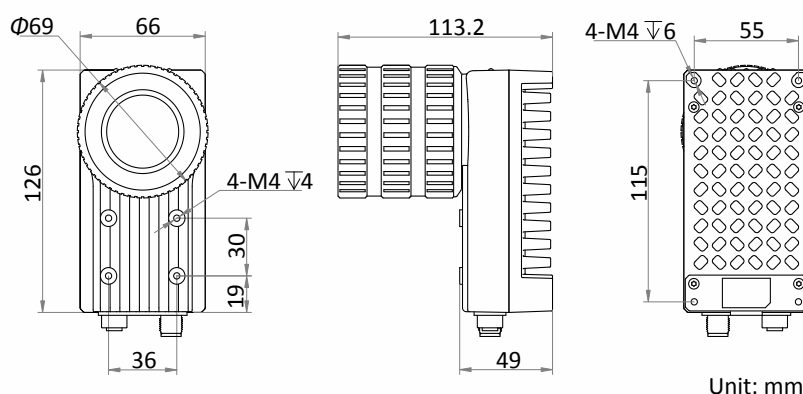

Specification

Model	MV-ID6120PM-00C-NNG
Performance	
Symbologies	1-dimensional codes: Code 39, Code 128, Code 93, ITF 25, CodaBar, EAN
	2-dimensional codes: QR, Data Matrix
Max. frame rate	28 fps @4096 × 3072
Max. reading speed	84 codes/sec
Sensor type	CMOS, global shutter
Pixel size	3.2 μm × 3.2 μm
Sensor size	1"
Resolution	4096 × 3072
Exposure time	16 μs to 1 sec
Gain	0 dB to 40 dB
Mono/color	Mono
Communication protocol	SmartSDK, TCP Client, TCP Server, Serial, FTP, HTTP
Electrical feature	
Data interface	Gigabit Ethernet
Digital I/O	12-pin M12 connector provides power and I/O, including opto-isolated input (LineIn 0/1/2) × 3, opto-isolated output (LineOut 0/1/2) × 3, RS-232 input × 1, and RS-232 output × 1
Power supply	12 VDC to 24 VDC
Max. power consumption	12 W@24 VDC
Mechanical	
Lens mount	C-mount
Light source	Not included
Lens cap	Included
Dimension	126 mm × 66 mm × 113.2 mm (5.0" × 2.6" × 4.5")
Weight	Approx. 750 g (1.7 lb.)
Ingress protection	IP67 (under proper installation of waterproof lens cap)
Temperature	Working temperature: 0 °C to 50 °C (32 °F to 122 °F)
	Storage temperature: -30 °C to 70 °C (-22 °F to 158 °F)
Humidity	20% to 95% RH, without condensation
General	
Client software	IDMVS
Certification	CE, FCC, RoHS