

Drehmomentsensor, reaktiv

DV-14

Torque Sensor, reactive

- Nenndrehmoment von 1 N·m ... 5000 N m
 - Genauigkeitsklasse optional 0,1% v. Endwert
 - Innen- und Außen- Normvierkant
 - Sehr kurze axiale Baulänge
 - Hohe Drehsteifigkeit
 - Zuverlässig und robust
 - Einfache Handhabung und Montage
 - Sonderausführungen auf Anfrage
- *Nominal torque from 1 N·m ... 5000 N·m*
 - *Accuracy class optional 0.1% f. scale*
 - *Standard male square and female square drive*
 - *Very short axial length*
 - *High torsional stiffness*
 - *Reliable and durable*
 - *Simple handling and assembly*
 - *Special versions on request*



Technische Daten - Specifications

Artikel -Nr. Article-No.	Nennmoment Nominal Torque [N·m]	Federkonstante Springrate [N·m/rad]	Massen- trägheits- moment Mass Moment of Inertia [kg·m ²]		Grenzlängskraft Limit Thrust Load [N]	Grenzquerkraft Limit Shear Force [N]
			Antriebsseite Drive Side	Messseite Test Side		
114365	1	2,1E+02	2,4E-07	3,9E-07	380	7
100323	2	2,1E+02	2,4E-07	3,9E-07	380	7
100322	5	5,5E+02	2,6E-07	4,0E-07	700	17
100321	12	6,9E+02	2,6E-07	4,1E-07	840	21,5
100320	25	4,7E+03	9,6E-06	2,2E-06	2100	83
100319	63	1,1E+04	9,9E-06	2,5E-06	3900	210
100318	100	1,8E+04	1,3E-05	3,3E-06	5300	300
100317	160	1,9E+04	1,4E-05	3,4E-06	5500	320
100960	200	1,9E+04	1,4E-05	3,4E-06	5500	320
100315	500	1,1E+05	1,1E-04	3,3E-05	14000	1100
100217	1000	1,2E+05	2,4E-04	6,0E-05	16500	950
100313	2000	4,6E+05	4,6E-03	9,8E-04	37000	1800
100312	5000	6,2E+05	4,7E-03	1,1E-03	55000	3400

DV-14		
Genauigkeitsklasse - Accuracy class	% v. E - f. s.	0,2
Reproduzierbarkeit - Repeatability (DIN 1319)	%	±0,02
Speisespannung - Excitation voltage	VDC	2 ... 12
Brückenwiderstand - Bridge resistance	Ω	350
Nennkennwert - Nominal sensitivity	mV/V	1 [1 N·m; 0,5] ±0,2%
Referenztemperatur - Reference temperature	°C	23
Nenntemperaturbereich - Nominal temperature range	°C	-5 ... 45
Gebrauchstemperaturbereich - Service temperature range	°C	-15 ... 55
Temp. koeff. des Nullsignals - Temp. coeff. of zero signal	% v. E./K - f. s./K	±0,02
Temp. koeff. des Kennwerts - Temp. coeff. of sensitivity	% v. E./K - f. s./K	±0,01
Gebrauchsdrehmoment (statisch) - Service torque (static)	% v. E - f. s.	150
Grenzdrehmoment (statisch) - Limit torque (static)	% v. E - f. s.	200
Bruchdrehmoment (statisch) - Ultimate torque (static)	% v. E - f. s.	>300
Schwingbreite - Bandwidth (DIN 50100)	% v. E - f. s.	70 (Spitze - Spitze) - (peak - peak)
Schutzart - Level of protection (DIN EN 60529)		IP50
Elektrischer Anschluss - Electrical connection		3 m, freien Lötenden - 3 m, free soldered ends

Anschlussbelegung - Pin Connection

Grün - Green	Speisung (-) - Excitation (-)
Braun - Brown	Speisung (+) - Excitation (+)
Gelb - Yellow	Signal (+) - Signal (+)
Weiß - White	Signal (-) - Signal (-)
Grau - Grey	Kontrollsignal (Option) - Control signal (option)
Schirm - Shield	Schirm - Shield

Optionen - Options

Artikel- Nr. - Article-No.	Bezeichnung - Description		
100933	Genauigkeitsklasse - Accuracy class	% v. E. - f. s.	0,1
100218	Kontrollsignal - Control signal	% v. E. - f. s.	100
42828	Erweiterter Temperaturbereich - Extended temperature range		-30 °C ... 100 °C
42829	Erweiterter Temperaturbereich - Extended temperature range		-30 °C ... 120 °C

Option Kalibrierungen - Option Calibrations

Artikel-Nr. - Article-No.	Bezeichnung - Description	Stufen - Steps	Norm - Norm
400676	Linearitätsdiagramm - Linearity diagram	25%	Werksnorm - Factory standard
400664	Linearitätsdiagramm - Linearity diagram	10%	
400961	Werkskalibrierung - Proprietary calibration	3	VDI/VDE 2646
400700	Werkskalibrierung - Proprietary calibration	5	
400688	Werkskalibrierung - Proprietary calibration	8	
	DAkkS-Kalibrierung - DAkkS-Calibration		auf Anfrage - on request

Mechanische Abmessungen - Dimensions

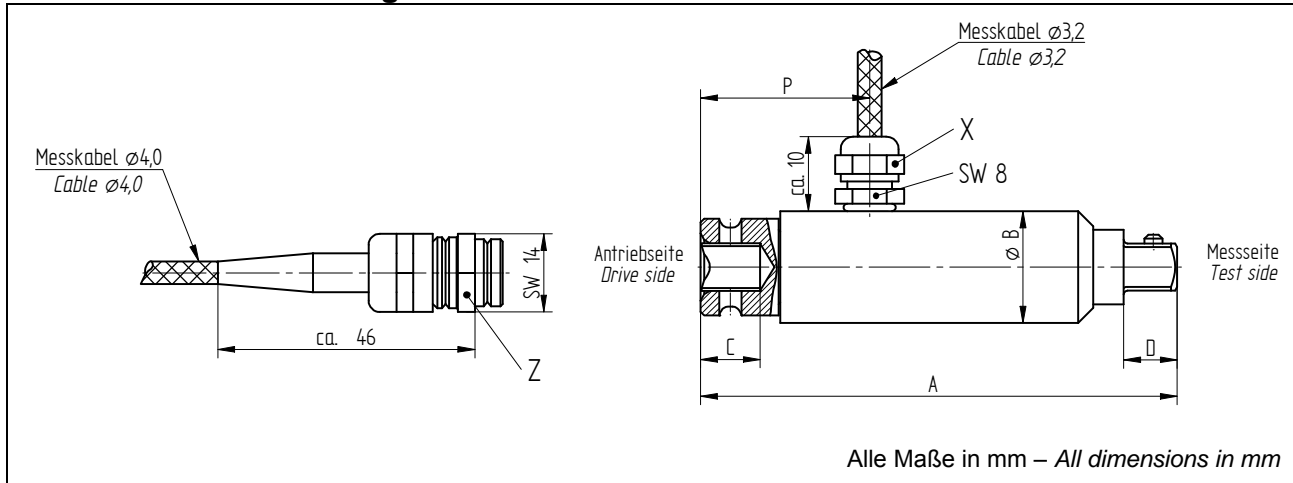

Nennrehmoment Nominal Torque [N·m]	Vierkant - Square	Abmessungen - Dimensions [mm]					Kabelverschraubung - Cable Connection
		A	ϕB	C	D	P	
1 / 2 / 5 / 12	1/4"	64	15	7,2	8	22,7	X
25 / 63	3/8"	71	30	10,4	12,2	34,5	X
100 / 160 / 200	1/2"	76	30	15,1	15	35	X
500	3/4"	100	49	22,9	24	46	X
1000	1"	132	49	27,4	27	60	X
2000 / 5000	1 1/2"	250	100	39	41,5	120	Z