

# Pressure Transducer

## Model 8103

Code:	8103 EN
Delivery:	2 - 3 weeks
Warranty:	24 months

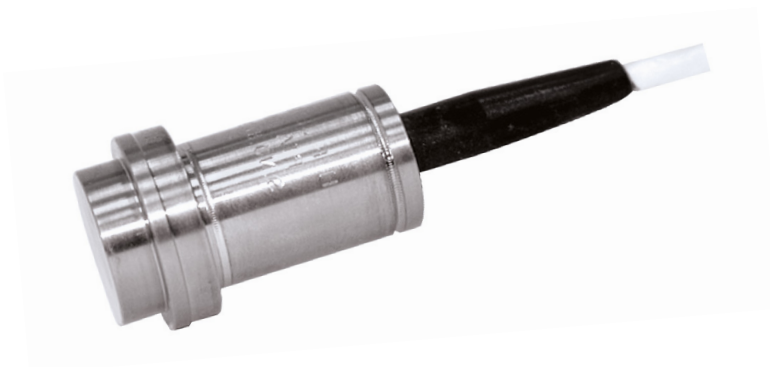

- Measuring ranges between 0 ... 5 bar and 0 ... 1000 bar
- Accuracy < 0.5 %
- Flush mounted diaphragm
- Made of titanium
- Not magnetic
- Protection class IP67

### Application

This transducer can be used anywhere thanks to its small size. Designed to work without a measuring chamber (uses a flush front diaphragm instead), this transducer is ideal for any measurements where the material to be measured may leave problematic residues. The range of suitable applications is even greater thanks to a choice of screw-on or weld-on adapters.

#### Areas of use:

- ▶ Bottling plants, food industry
- ▶ Mixing facilities for the chemicals industry
- ▶ Pharmaceuticals
- ▶ Cosmetics industry
- ▶ Bioengineering

### Description

These pressure transducers are made entirely of titanium and therefore have outstanding resistance to corrosion. These convert the pressure-induced deflection of the diaphragm into a change in electrical resistance, which can be amplified, measured and processed by external electronic circuitry. The transducers come in a choice of measuring ranges: up to 20 bar for measurements with respect to atmospheric pressure, or a range of 50 bar and above for measurements with respect to a sealed atmosphere.

**Technical Data**

Order Code	* Measuring Range	Resonance Frequency [kHz]
8103-5005	0 ... 5 bar	28
8103-5010	0 ... 10 bar	28
8103-5020	0 ... 20 bar	36
8103-5050	0 ... 50 bar	54
8103-5100	0 ... 100 bar	77
8103-5200	0 ... 200 bar	108
8103-5500	0 ... 500 bar	160
8103-6001	0 ... 1000 bar	229

**Electrical values**

Bridge resistance: foil strain gauge  $1000 \Omega \pm 0.5 \%$   
 Excitation voltage: 5 V, max. 10 VDC or AC  
 Nominal sensitivity:  
   measuring range 0 ... 5 bar 1 mV/V, nominal  
   measuring range  $\geq 0 \dots 10$  bar 2 mV/V, nominal

**Environmental conditions**

Limit temperature range:  $-55 \text{ }^\circ\text{C} \dots 150 \text{ }^\circ\text{C}$   
 Nominal temperature range:  $0 \text{ }^\circ\text{C} \dots 100 \text{ }^\circ\text{C}$   
 Influence of temperature on zero:  
   measuring range 0 ... 5 bar  $< \pm 0.04 \%$  F.S./K  
   measuring range  $\geq 0 \dots 10$  bar  $< \pm 0.02 \%$  F.S./K  
 Influence of temperature on sensitivity:  $< \pm 0.02 \%$  F.S./K

**Mechanical values**

Accuracy:  
 Combined error consisting of non linearity, hysteresis and variation  $< \pm 0.5 \%$  F.S.

Kind of measurement:  
   measuring range  $\leq 20$  bar against atmosphere  
   measuring range  $\geq 50$  bar against sealed atmosphere

Measuring ranges: refer to table

Overload: 400 % over capacity

Dynamic performance:  
   recommended 70 % of capacity  
   maximum 100 % of capacity

Design: pressure transducer with flush mounted diaphragm

Material: diaphragm and housing made of titanium grade 5 (Material 3.7165)

Pressure connector: refer to accessories, threaded and welding adapter

Sealing:  
 The sealing of the transducer is made by an O-ring 18.77 x 1.78 (Shore 90), which is included in scope of delivery. The use of a support ring is recommended for dynamic pressures of above 200 bar.

Mounting torque: 2 Nm

Protection class acc. to EN 60529: IP67

Sock resistance acc. to IEC 60068-2-27: 1000 g/1 msec.

Vibration resistance acc. to IEC 60068-2-6: max. 30 g at 10 ... 2000 Hz

Surface roughness:  $> 0.4 \mu\text{m}$

Dimensions: see dimensional drawing

Weight: 40 g

Electrical connection:  
 shielded, Teflon isolated cable, color coded with open ends for soldering, bending radius  $> 30$  mm, length 2 m

Wiring code:

Color	
red	excitation +
blue	excitation -
green	signal +
yellow	signal -

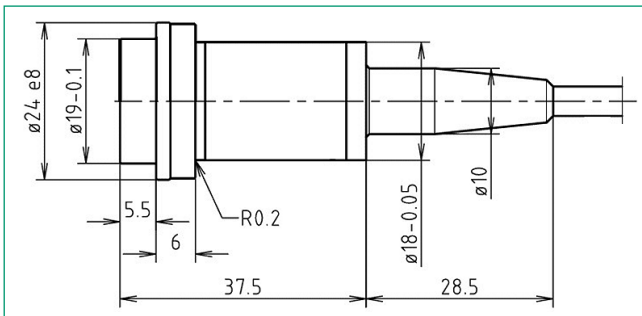
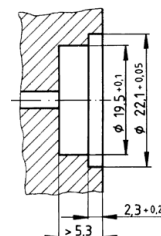
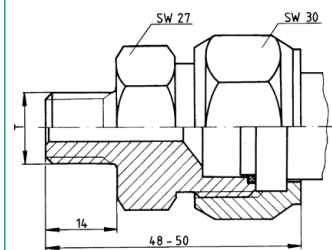
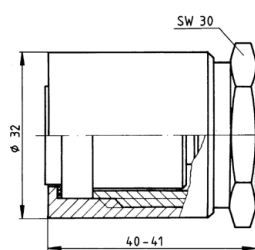
**Dimensional drawing**

**Recommended installation**

**Threaded adapter model 8103-Z005**

**Welding adapter model 8103-Z003**

**Order Information**

Pressure transducer, measuring range 20 bar **Model 8103-5020**

**Accessories**

O-ring, Shore 90 A, Nitril Butadin **Model 8103-Z001**

Support ring made of polycarbonat **Model 8103-Z002**

Welding adapter with O-ring, material 1.4057, refer to drawing **Model 8103-Z003**

O-ring PTFE (Teflon) **Model 8103-Z004**

Threaded adapter with O-ring, material Sandviken 1802 (SIS 2382) with connecting thread  $T = 1/4''$ , refer to drawing **Model 8103-Z005**

**Test and Calibration Certificate**

Included in delivery, et al. with specification of zero output, sensitivity and shunt calibration factor.

**Factory Calibration Certificate (WKS)**

Calibration of a pressure transducer separately as well as connected to an indicator. Standard is a certificate with 11 points, starting at zero, running up and down in 20% increments and covering the complete measuring range. Special calibrations on request. Calculation of costs by base price plus additional costs per point.

**Order Code 81WKS-81XX**