

# AC SERVO PRESS

New Model 2kN !

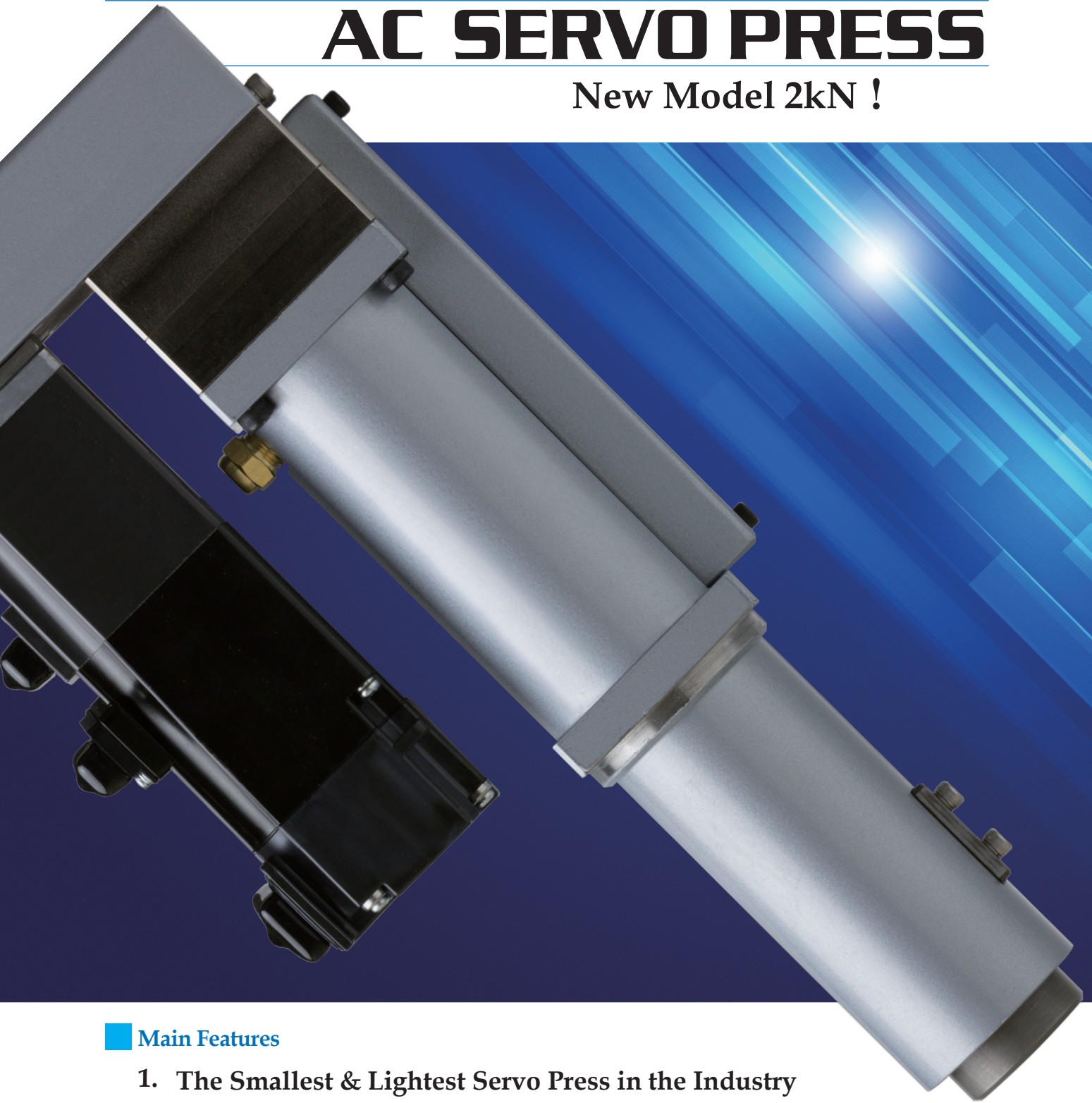

## Main Features

1. The Smallest & Lightest Servo Press in the Industry
2. Capable of Tension & Compression
3. Constant Load Can Maintain Force
4. Auto Program Generation for Quick & Easy Programming
5. Freely Programmable for more Complex Tasks



# The Smallest & Lightest Servo Press in the Industry

## Example Applications

- Forming
- Electronics
- Clinching
- Assembly - Molding
- Die Press
- Bushing Press

## Specifications

Model No.	MS02-100B
Max Force (kN) Cont. Max	2
Force*1 (kN)	1.5
Stroke (MM)	100
Speed (mm/s)	225
Load Accuracy Position	±1.5% @ Load Cell FS
Repeatability Operating	±0.01mm (under identical load)
Temp./Humidity	0~45°C/85% or less (no condensation)
Power Consumption (kVA)	0.3
Weight (Kg)	3.5

## Dimensions

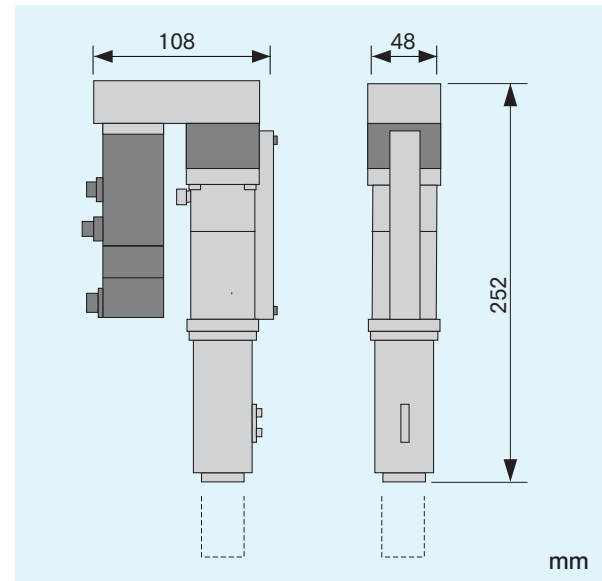

## System Overview

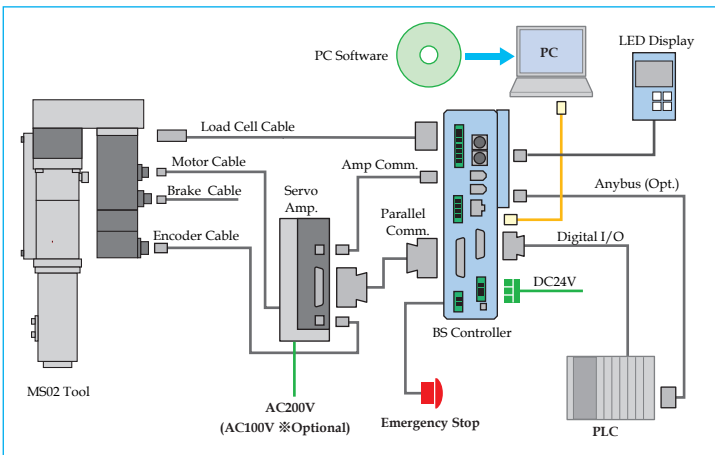

## Auto Generation Feature

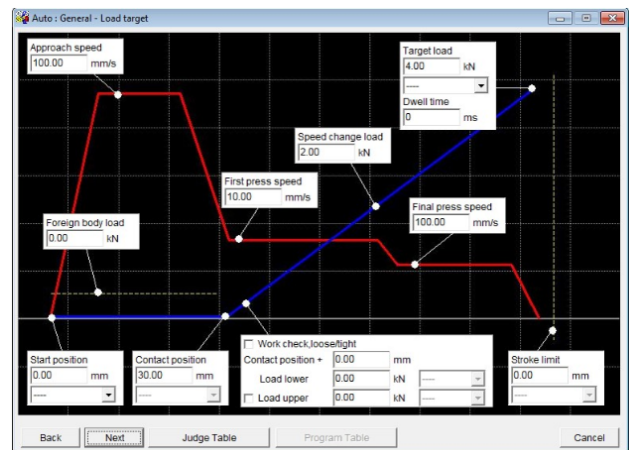

## Where Capability and Simplicity Meet

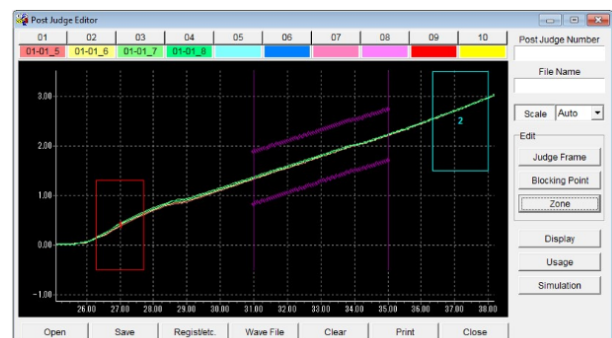

## 100% Process Monitoring

